

DC Electronic Ballast using Flyback Converter for Fluorescent T5 Lamp

Sarayoot Thongkullaphat¹, Patcharanan Sritanauthaikorn²

^{1,2}Department of Electrical Engineering, Faculty of Engineering and Architecture,
Rajamangala University of Technology Suvarnabhumi, Thailand.

¹sarayoot.t@rmutsb.ac.th

Abstract: This paper presents a DC electronic ballast for fluorescent T5 lamp. The electronic ballast is designed using with 12 volts battery. The design of electronic ballast circuit is comprised with flyback converter circuit that increasing the directcurrent from 12 volts to 250 volts. The inverter operates with the resonance circuit for starting the fluorescent lamp. The control circuit uses switching frequency at 50 kHz while the brightness test of the fluorescent lamps is at a distance of 1 meter from lux meter. The experimental results of this electronic ballast circuit in the case of 12 VDC input are light intensity about 172.9 lux at 29.7 W of input power and 28 W for output power. Therefore, an efficiency of this electronic ballast is 94.72% at the full power output.

Keywords: Electronic Ballast, Fluorescent T5 lamp, Flyback Converter.

1. INTRODUCTION

Nowadays, the fluorescent lamps are used worldwide because they provide good color and light more than incandescent lamp. The market share of the fluorescent T8 and T5 lamp is the largest. because of their high efficiency [lm/w] and light more than the incandescent lamp and other bulbs at the same power. However, Today, Performance of T5 fluorescent tube is better than T8 in terms of efficiency, color render index (CRI) and smaller size of T5 lamps allows for smaller luminaries [1]. Fluorescent lamp is a gas-discharge bulb which needs ballast connected in order to ignite and also adjust suitable voltage and current for its power [2]. The electronic ballast is designed with 12 volts battery has low DC voltage, up to high voltage DC with

flyback converter [3]. Therefore, the ballast that used flyback converter circuit increasing the direct voltage from 12 volts to 250 volts to send to the inverter of the light bulb. Electronic ballast composes from electronic devices to operate at high output frequency. Results are smoother and more intensive than the output from conventional ballast. In electronic ballast circuit, the inductive part of resonant circuit for triggering fluorescent lamp is small and light but nowadays electronic ballast uses ICs to control power electronic switches [4],

2. CONCEPT OF ELECTRONICS BALLAST

Electronic ballast has produced the driving signal from battery 12 Vdc and resonant circuit feeding to half-bridge inverter circuit. The frequency fed to electronic ballast is converted from DC source to 50 kHz to trigger the electronic ballast of fluorescent lamp. Block diagrams of basic structure of electronic ballast and conventional ballast are shown in Fig 1. The functions of each part are as follows:

1. Converter stage: this stage has converted DC low voltage, from 12 Vdc battery to DC high voltage DC-to-DC converter by flyback converter circuit.
2. Inverter and Driving Stage: this stage acts as high frequency inverter (DC-to-AC converter) by using half bridge inverter at frequency of 50 kHz which will be tuned for the proper frequency. This circuit is for triggering and controlling the lamp in the steady state by using DC-to-AC inverter to produce high frequency for resonant circuit in the lamp driving state.

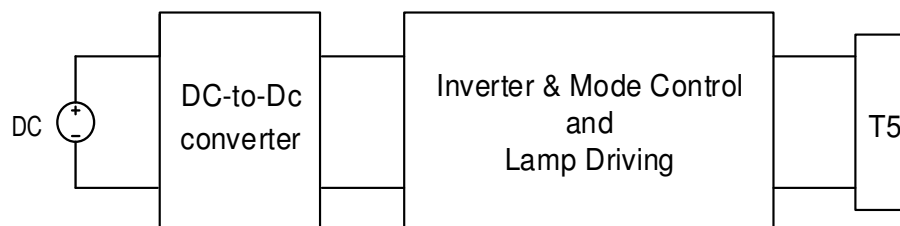

Fig. 1. General block diagram of electronic ballast.

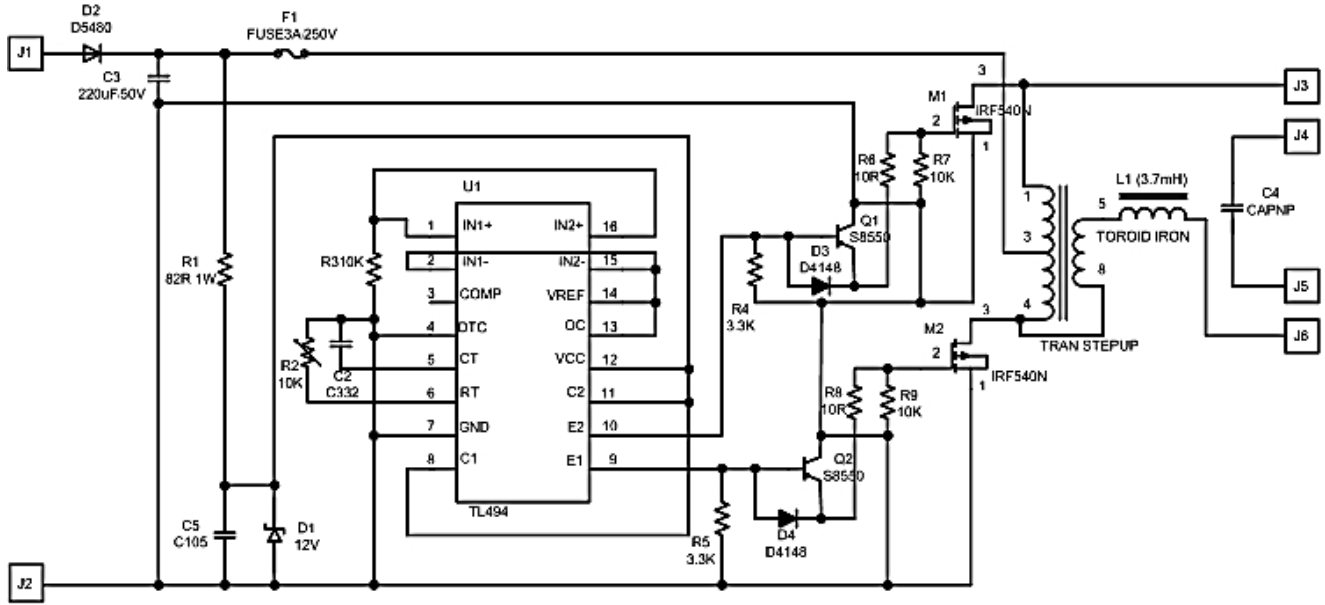

Fig. 2. Proposed DC Electronic Ballast using Flyback Converter for T5 lamp

When DC voltage 12 volt applied to electronic ballast circuit, the frequency generator has produced high-frequency signal, which will drive the transistor to operate interchangeably. The inductors and capacitor resonant circuit crossed the tube have established the frequency. The electronic ballast should have the output frequency in 50 kHz range to prevent interference and radio frequency noise. To create a PWM signal is by the IC number TL494 with 50% duty cycle. This PWM signal has increased the luminous efficiency of T5 lamps and can reduce the tube losses down to 10%.

3. DESIGN OF ELECTRONIC BALLAST CIRCUIT

The calculation of the electronic ballast with circuit low direct current voltage for T5 lamps is followed:

3.1 FLYBACK CONVERTER

To design the circuit fly back converter with input voltage of 12 V, the output voltage is 250 volts, 2 amps and electric current frequency is 50 kHz.

Calculating the working period is,

$$T_{on} = 0.5T = 20 \times 10^{-6} \times 0.5 = 10 \times 10^{-6} \text{ s.}$$

The ratio of around

$$V_{DS} = V_{in(max)} + \frac{N_p}{N_s} (V_o + V_p) + 0.3V_{in(max)}$$

$$250 = 12 + \frac{N_p}{N_s} (250 + 1.5) + 0.3 \times 12$$

$$\frac{N_p}{N_s} = \frac{234.4}{251.5} = 0.932.$$

The inductance of the coil primary, L_p . Number of turns of the primary coil and second coil

$$L_p = \frac{\eta [(V_{in(min)} - V_{CE(set)}) \times t_{ON(max)}]^2}{2T \times P_{out}} = \frac{0.8 [(12-1) \times 10 \times 10^{-6}]^2}{2(10 \times 10^{-6}) \times 250} = 1.936 \times 10^{-6} \text{ H}$$

$$N_p = \frac{(V_{in(min)} - V_{CE(set)}) t_{on(max)} \times 10^8}{\Delta B_{max} \times A_e} = \frac{(12-1)(10 \times 10^{-6} \times 10^8)}{470.58 \times 0.85} = 27.5$$

Turns

where

$$\Delta B = \frac{V_{out} \times T}{N_p \times A_e} \times 10^8 = \frac{250 \times (10 \times 10^{-6}) \times 10^8}{30 \times 0.85} = 470.58$$

$$N_s = \frac{N_p}{1} = \frac{27.5}{1} = 27.5 \approx 28 \text{ Turn.}$$

3.2 INVERTER CIRCUIT

This circuit exploits Class D Half-Bridge Inverter Circuit is shown in Fig. 2 using 2 switches to drive circuit with continuous alternate operation switch 1 is on while switch 2 is off and vice versa.

3.3 RESONANT INDUCTOR AND CAPACITOR

Load of class D inverter is Series-Resonant Parallel-Load. In the absolute circuit, capacitor can be connected in series

as shown in Fig. 2. Resonant frequency can be found when $X_L = X_C$ as stated in equation.

$$f_r = \frac{1}{2\pi\sqrt{L_1 C_4}}$$

In resonant circuit, C_4 and L_1 will be in series and both of them will be connected in parallel with fluorescent load. Their values can be changed according to fluorescent size and can be calculated as stated in equations.

$$C_4 = \frac{1}{4\pi^2 f_r^2 L_1} \text{ and } L_1 = \frac{1}{4\pi^2 f_r^2 C_4}$$

4. EXPERIMENTAL RESULTS

To experimentally verify the theoretical derivation, electronic ballast with 12 Vdc input and a 28 Watt fluorescent T5 lamp was implemented. The proposed ballast circuit was shown in Fig. 2. The proposed ballast parameters ballast "A" as power (W) and light intensity (Lux). They are shown in Table 1. The intensity of light bulb at height of 1 meter, 2 meters and 3 meters from bulb were measured as shown in Fig. 3.

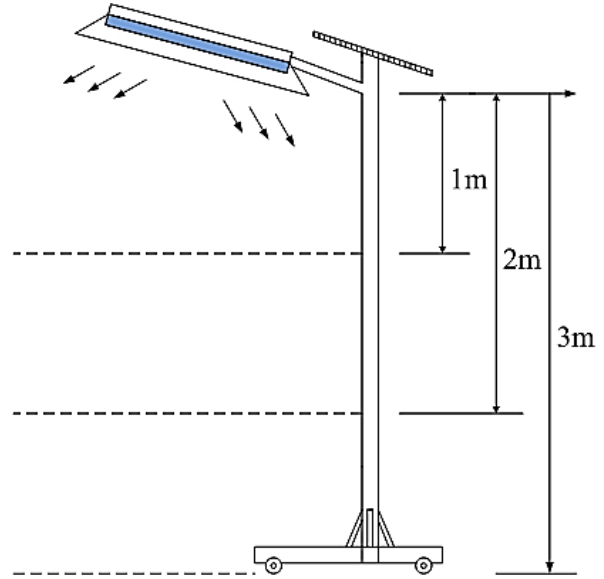

Fig. 3. The intensity measurement of light in various electronic ballasts.

TABLE 1: Comparison of the power and intensity of the light bulb T5.

Height (m)	Electronics ballast (A)		Proposes electronics ballast	
	Power input (W)	Light intensity(Lux)	Power input (W)	Light intensity(Lux)
1	30.8	175.23	29.57	175.27
2	30.8	59.27	29.57	60.19
3	30.8	37.53	29.57	38.23

Table 1, Comparison of a series of electronic ballasts for T5 lamps low voltage DC in proposes to see that the series DC electronic ballast to the light intensity close to the ballast electronics.

TABLE 2: Comparison of the performance of ballast

Ballast types	V_{in} (V)	I_{in} (A)	P_{in} (W)	V_{out} (Vac)	I_{out} (Vac)	P_{out}	η
DC electronic ballast for low voltage T5 lamp	12Vdc	2.47A dc	29.57	163.8	0.175	28	94.72%
Electronics Ballast A	220Vac	0.15 A ac	32.78	170	0.165	28	85.41%

Note: Electronics Ballast A is general ballast sample in market.

The results of input and out parameters of the proposed ballast and ballast A Shown in table 2. They were tested in the same condition. This experimental results showed that they delivered the same power but the efficiency of the low input DC voltage ballast is better.

5. CONCLUSIONS

The low-DC-voltage electronic ballast for a 28 W T5 lamp is able to reduce power loss. The main driving circuit is 12 Vdc to 250 Vdc converter that composed of flyback converter and inverter Class D resonant circuit. The

experiment results showed that the intensity of 28 W, T5 fluorescent lamp at distance 1, 2 and 3 meter is 175.27, 60.19 and 38.23 lux, respective. The inputs of the proposed ballast are 12 Vdc and 2.47 A. Lighting of the test set is depended on PWM signal with 50 kHz switching frequency, 50% duty cycle. The efficiency of more than 90% at full power.

ACKNOWLEDGEMENT

This work was supported by the Rajamangala University of Technology Suvarnabhumi (RMUTSB).

REFERENCES

- [1] Cheong, C. K.; Cheng, K.; W. E. and Chan, H. L. Examination of T8 – T5 Electronic Ballast Adaptor. *Proc. ICPEESA'06*, pp. 170-172, 2006.
- [2] Edward, E. H.; Terry, K. M. Characteristics of Various F40 Fluorescent Systems at 60 Hz and High Frequency. *IEEE Trans. Ind. Appl.*, 1985, IA-21, (1), pp. 11-16.
- [3] Junming, Z.; Zhaoming, Q. A High Efficiency Flyback Converter with New Active Clamp Technique. *IEEE Trans. on Power Electronics*, 2010, pp. 1775-1785.
- [4] Jung-Min, K.; Woo-Young, C. and Bong-Hwan, K. Single-Stage Quasi-Resonant Flyback Converter for a Cost-Efficiency PDP Sustain Power Module. *IEEE Trans. Ind.*, 2011, pp. 2372-2377.